

Features

- Planar Die Construction
- Halogen Free. "Green" Device (Note 1)
- Moisture Sensitivity Level 1
- Epoxy Meets UL 94 V-0 Flammability Rating
- Lead Free Finish/RoHS Compliant ("P" Suffix Designates RoHS Compliant. See Ordering Information)

**200 mW
Zener Diode
2.4 to 39 Volts**

Maximum Ratings

- Operating Junction Temperature Range: -65°C to +150°C
- Storage Temperature Range: -65°C to +150°C
- Thermal Resistance :625°C/W Junction to Ambient

Parameter	Symbol	Rating	Conditions
Power Dissipation	P_D	200mW	
Maximum Forward Voltage	V_F	0.9V	$I_F=10mA$

Note: 1. Halogen free "Green" products are defined as those which contain <900ppm bromine, <900ppm chlorine (<1500ppm total Br + Cl) and <1000ppm antimony compounds.

SOD-523

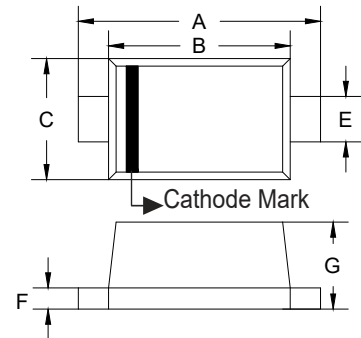

DIM	INCHES		MM		NOTE
	MIN	MAX	MIN	MAX	
A	0.059	0.067	1.50	1.70	
B	0.043	0.051	1.10	1.30	
C	0.030	0.033	0.75	0.85	
E	0.010	0.014	0.25	0.35	
F	0.003	0.008	0.08	0.20	
G	0.020	0.026	0.50	0.65	

Suggested Solder Pad Layout

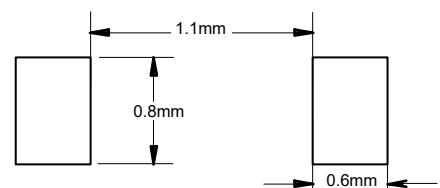

Electrical Characteristics @ 25°C Unless Otherwise Specified

MCC Part Number ⁽⁴⁾	Zener Voltage ⁽²⁾			Maximum Zener Impedance ⁽³⁾		Maximum Zener Impedance ⁽³⁾		Maximum Reverse Current		Typical Temperature Coefficient @ I _{ZT}		Marking Code ⁽⁴⁾
	V _Z @ I _{ZT}			I _{ZT}	Z _{ZT}	I _{ZK}	Z _{ZK}	I _R	V _R	Min	Max.	
	Min.(V)	Nom(V)	Max.(V)	mA	Ω	mA	Ω	Max.(μA)	V	mV/°C		
BZT52C2V4T	2.28	2.4	2.56	5	100	1.0	600	50	1.0	-3.5	0	Z11
BZT52C2V7T	2.5	2.7	2.9	5	100	1.0	600	20	1.0	-3.5	0	Z12
BZT52C3V0T	2.8	3.0	3.2	5	95	1.0	600	10	1.0	-3.5	0	Z13
BZT52C3V3T	3.1	3.3	3.5	5	95	1.0	600	5	1.0	-3.5	0	Z14
BZT52C3V6T	3.4	3.6	3.8	5	90	1.0	600	5	1.0	-3.5	0	Z15
BZT52C3V9T	3.7	3.9	4.1	5	90	1.0	600	3	1.0	-3.5	0	Z16
BZT52C4V3T	4.0	4.3	4.6	5	90	1.0	600	3	1.0	-3.5	0	Z17
BZT52C4V7T	4.4	4.7	5.0	5	80	1.0	500	3	2.0	-3.5	0.2	Z1
BZT52C5V1T	4.8	5.1	5.4	5	60	1.0	480	2	2.0	-2.7	1.2	Z2
BZT52C5V6T	5.2	5.6	6.0	5	40	1.0	400	1	2.0	-2.0	2.5	Z3
BZT52C6V2T	5.8	6.2	6.6	5	10	1.0	150	3	4.0	0.4	3.7	Z4
BZT52C6V8T	6.4	6.8	7.2	5	15	1.0	80	2	4.0	1.2	4.5	Z5
BZT52C7V5T	7.0	7.5	7.9	5	15	1.0	80	1	5.0	2.5	5.3	Z6
BZT52C8V2T	7.7	8.2	8.7	5	15	1.0	80	0.7	5.0	3.2	6.2	Z7
BZT52C9V1T	8.5	9.1	9.6	5	15	1.0	100	0.5	6.0	3.8	7.0	Z8
BZT52C10T	9.4	10	10.6	5	20	1.0	150	0.2	7.0	4.5	8.0	Z9
BZT52C11T	10.4	11	11.6	5	20	1.0	150	0.1	8.0	5.4	9.0	Y1
BZT52C12T	11.4	12	12.7	5	25	1.0	150	0.1	8.0	6.0	10.0	Y2
BZT52C13T	12.4	13	14.1	5	30	1.0	170	0.1	8.0	7.0	11.0	Y3
BZT52C15T	13.8	15	15.6	5	30	1.0	200	0.1	10.5	9.2	13.0	Y4
BZT52C16T	15.3	16	17.1	5	40	1.0	200	0.1	11.2	10.4	14.0	Y5
BZT52C18T	16.8	18	19.1	5	45	1.0	225	0.1	12.6	12.4	16.0	Y6
BZT52C20T	18.8	20	21.2	5	55	1.0	225	0.1	14.0	14.4	18.0	Y7
BZT52C22T	20.8	22	23.3	5	55	1.0	250	0.1	15.4	16.4	20.0	Y8
BZT52C24T	22.8	24	25.6	5	70	1.0	250	0.1	16.8	18.4	22.0	Y9
BZT52C27T	25.1	27	28.9	2	80	0.5	300	0.1	18.9	21.4	25.3	Y10
BZT52C30T	28	30	32	2	80	0.5	300	0.1	21.0	24.4	29.4	Y11
BZT52C33T	31	33	35	2	80	0.5	325	0.1	23.1	27.4	33.4	Y12
BZT52C36T	34	36	38	2	90	0.5	350	0.1	25.2	30.4	37.4	Y13
BZT52C39T	37	39	41	2	130	0.5	350	0.1	27.3	33.4	41.2	Y14

- Note :
2. Tested with pulses, period = 5ms, pulse width=300us
 3. f=1KHz
 4. Standard Zener voltage tolerance is ±5% with a "C" suffix (e.g.: BZT52C2V4T),suffix "B" is ± 2 % tolerance (e.g.: BZT52B2V4T)

Electrical Characteristics @ 25°C Unless Otherwise Specified

MCC Part Number ⁽⁴⁾	Zener Voltage ⁽²⁾			Maximum Zener Impedance ⁽³⁾		Maximum Zener Impedance ⁽³⁾		Maximum Reverse Current		Typical Temperature Coefficient @ I _{ZT}		Marking Code ⁽⁴⁾
	V _Z @ I _{ZT}			I _{ZT}	Z _{ZT}	I _{ZK}	Z _{ZK}	I _R	V _R	Min	Max.	
	Min.(V)	Nom(V)	Max.(V)	mA	Ω	mA	Ω	Max.(μA)	V	mV/°C		
BZT52B2V4T	2.35	2.4	2.45	5	100	1.0	600	50	1.0	-3.5	0	.Z11
BZT52B2V7T	2.65	2.7	2.75	5	100	1.0	600	20	1.0	-3.5	0	.Z12
BZT52B3V0T	2.94	3.0	3.06	5	95	1.0	600	10	1.0	-3.5	0	.Z13
BZT52B3V3T	3.23	3.3	3.37	5	95	1.0	600	5	1.0	-3.5	0	.Z14
BZT52B3V6T	3.53	3.6	3.67	5	90	1.0	600	5	1.0	-3.5	0	.Z15
BZT52B3V9T	3.82	3.9	3.98	5	90	1.0	600	3	1.0	-3.5	0	.Z16
BZT52B4V3T	4.21	4.3	4.39	5	90	1.0	600	3	1.0	-3.5	0	.Z17
BZT52B4V7T	4.61	4.7	4.79	5	80	1.0	500	3	2.0	-3.5	0.2	.Z1
BZT52B5V1T	5.00	5.1	5.20	5	60	1.0	480	2	2.0	-2.7	1.2	.Z2
BZT52B5V6T	5.49	5.6	5.71	5	40	1.0	400	1	2.0	-2.0	2.5	.Z3
BZT52B6V2T	6.08	6.2	6.32	5	10	1.0	150	3	4.0	0.4	3.7	.Z4
BZT52B6V8T	6.66	6.8	6.94	5	15	1.0	80	2	4.0	1.2	4.5	.Z5
BZT52B7V5T	7.35	7.5	7.65	5	15	1.0	80	1	5.0	2.5	5.3	.Z6
BZT52B8V2T	8.04	8.2	8.36	5	15	1.0	80	0.7	5.0	3.2	6.2	.Z7
BZT52B9V1T	8.92	9.1	9.28	5	15	1.0	100	0.5	6.0	3.8	7.0	.Z8
BZT52B10T	9.80	10	10.20	5	20	1.0	150	0.2	7.0	4.5	8.0	.Z9
BZT52B11T	10.78	11	11.22	5	20	1.0	150	0.1	8.0	5.4	9.0	.Y1
BZT52B12T	11.76	12	12.24	5	25	1.0	150	0.1	8.0	6.0	10.0	.Y2
BZT52B13T	12.74	13	13.26	5	30	1.0	170	0.1	8.0	7.0	11.0	.Y3
BZT52B15T	14.70	15	15.30	5	30	1.0	200	0.1	10.5	9.2	13.0	.Y4
BZT52B16T	15.68	16	16.32	5	40	1.0	200	0.1	11.2	10.4	14.0	.Y5
BZT52B18T	17.64	18	18.36	5	45	1.0	225	0.1	12.6	12.4	16.0	.Y6
BZT52B20T	19.60	20	20.40	5	55	1.0	225	0.1	14.0	14.4	18.0	.Y7
BZT52B22T	21.56	22	22.44	5	55	1.0	250	0.1	15.4	16.4	20.0	.Y8
BZT52B24T	23.52	24	24.48	5	70	1.0	250	0.1	16.8	18.4	22.0	.Y9
BZT52B27T	26.46	27	27.54	2	80	0.5	300	0.1	18.9	21.4	25.3	.Y10
BZT52B30T	29.40	30	30.60	2	80	0.5	300	0.1	21.0	24.4	29.4	.Y11
BZT52B33T	32.34	33	33.66	2	80	0.5	325	0.1	23.1	27.4	33.4	.Y12
BZT52B36T	35.28	36	36.72	2	90	0.5	350	0.1	25.2	30.4	37.4	.Y13
BZT52B39T	38.22	39	39.78	2	130	0.5	350	0.1	27.3	33.4	41.2	.Y14

Note :

2. Tested with pulses, period = 5ms, pulse width=300us
3. f=1KHz
4. Standard Zener voltage tolerance is ±5% with a "C" suffix (e.g.: BZT52C2V4T),suffix "B" is ± 2 % tolerance (e.g.: BZT52B2V4T)

Curve Characteristics

Fig. 1 - Power Derating Curve

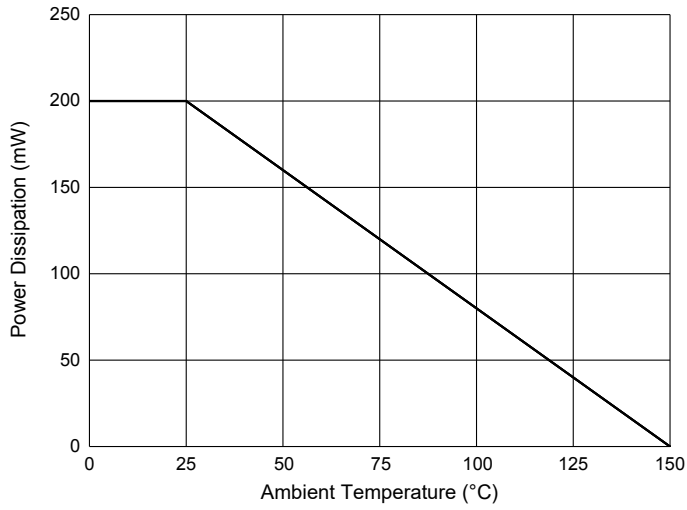

Fig. 2 - Typical Zener Breakdown Characteristics

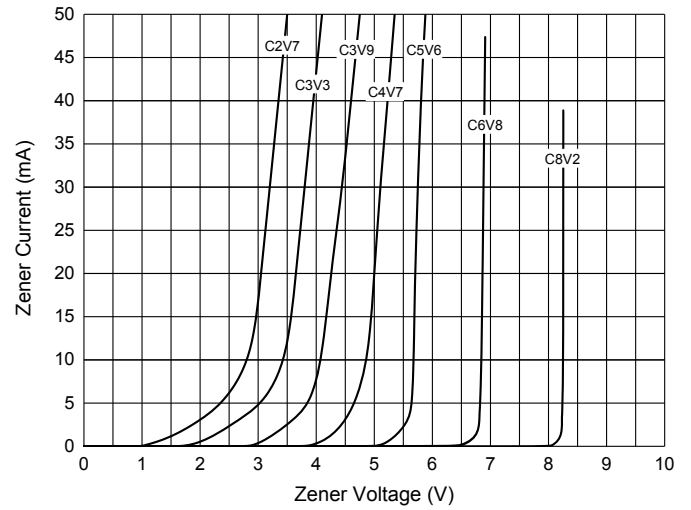
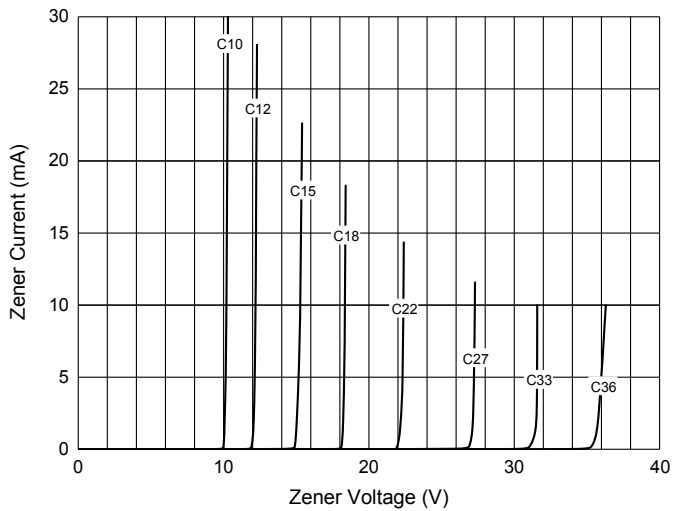

Fig. 3 - Typical Zener Breakdown Characteristics



Ordering Information

Device	Packing
Part Number-TP	Tape&Reel:8Kpcs/Reel

IMPORTANT NOTICE

Micro Commercial Components Corp. reserves the right to make changes without further notice to any product herein to make corrections, modifications , enhancements , improvements , or other changes . **Micro Commercial Components Corp.** does not assume any liability arising out of the application or use of any product described herein; neither does it convey any license under its patent rights ,nor the rights of others . The user of products in such applications shall assume all risks of such use and will agree to hold **Micro Commercial Components Corp.** and all the companies whose products are represented on our website, harmless against all damages. **Micro Commercial Components Corp.** products are sold subject to the general terms and conditions of commercial sale, as published at <https://www.mccsemi.com/Home/TermsAndConditions>.

LIFE SUPPORT

MCC's products are not authorized for use as critical components in life support devices or systems without the express written approval of Micro Commercial Components Corporation.

CUSTOMER AWARENESS

Counterfeiting of semiconductor parts is a growing problem in the industry. Micro Commercial Components (MCC) is taking strong measures to protect ourselves and our customers from the proliferation of counterfeit parts. MCC strongly encourages customers to purchase MCC parts either directly from MCC or from Authorized MCC Distributors who are listed by country on our web page cited below. Products customers buy either from MCC directly or from Authorized MCC Distributors are genuine parts, have full traceability, meet MCC's quality standards for handling and storage. **MCC will not provide any warranty coverage or other assistance for parts bought from Unauthorized Sources.** MCC is committed to combat this global problem and encourage our customers to do their part in stopping this practice by buying direct or from authorized distributors.